

Utilizing Silicon Carbide in 80 Plus Current Average Power Factor Correction

John Bendel

Abstract

In an attempt to improve the efficiency and power factor of computing power supplies, the computer industry has created a voluntary certification program called “80 Plus”. In this application note, a silicon carbide cascode switch and boost diode will be evaluated in a 1 kW hard switch Power Factor Correction (PFC) board with respect to its suitability in 80 Plus applications.

1 80 Plus

Table 1 gives the basic efficiency levels required for the various 80 Plus ratings. It is important to remember that these efficiencies are for the entire supply and not just for the PFC stage; therefore the PFC must significantly exceed the efficiencies in this chart. With respect to power factor, 0.90 or better is required for 20%, 50% and 100% of rated load with the exception of Platinum, which requires at least 0.95 power factor for servers.

80 Plus Test Type	115V internal non-redundant				230V internal redundant				230V EU internal non-redundant			
	10%	20%	50%	100%	10%	20%	50%	100%	10%	20%	50%	100%
80 Plus		80%	80%	80%						82%	85%	82%
80 Plus Bronze		82%	85%	82%		81%	85%	81%		85%	88%	85%
80 Plus Silver		85%	88%	85%		85%	89%	85%		87%	90%	87%
80 Plus Gold		87%	90%	87%		88%	92%	88%		90%	92%	89%
80 Plus Platinum		90%	92%	89%		90%	94%	91%		92%	94%	90%
80 Plus Titanium	90%	92%	94%	90%	90%	94%	96%	91%	90%	94%	96%	94%

Table 1 80 Plus efficiency level certification requirements

2 Power Factor Correction Topology

This note will use a hard switch current average PFC, as shown in Figure 1. These designs are simple low cost solutions and suitable up to the 80 Plus, Gold level, and, depending on the switching frequency and power level, it is plausible to meet the Platinum level, or higher.

The main drawback of this topology is that it will always carry the losses from the bridge. Ideal efficiency solutions reside in the more complex bridgeless topology. The “bridgeless” discussion is beyond the scope of this note, but if the highest efficiency is required; the reader is encouraged to look through UnitedSiC and other web material on bridgeless PFC implementations.

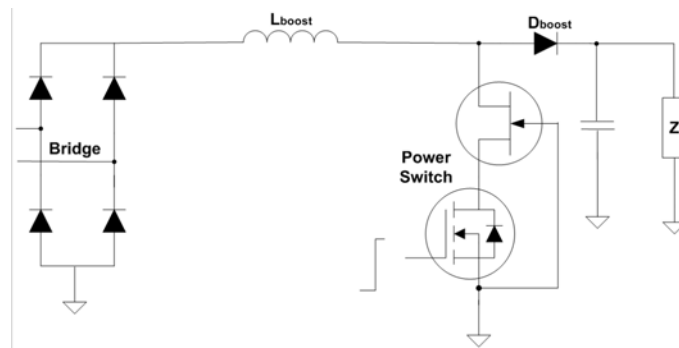

Figure 1: Basic power factor correction topology

3 The Test Board



Figure 2: UCC3818-based PFC test board

Figure 2 is a picture of the test board that produced the data presented in this note. The Power Switch is a UJC06505K Cascode (650V, 45 mOhm maximum). The advantage of the UJC06505K is not only its fast switching capability, but it can also be driven with standard gate drive. Its performance capability allows SiC to compete economically against silicon solutions. An R_{G_ON} of 15 Ohms and R_{G_OFF} of 51 Ohms are used to minimize EMI issues, and all gate drive levels are 0 to 14 V.

A complete list of components and alternative commercial inductors can be found on USiC's 90-260 VAC PFC webpage, found in the application section. An interactive Mathcad file based on Texas Instruments calculation is also available from the USiC website.

An USiC Silicon Carbide Diode, UJD06510TS (650 V, 10 A) with a Q_C of 16 nC will be used as the boost diode. The inductor is $\sim 350 \mu\text{H}$ at rated current. The Inductor is implemented with a Magnetics Inc. 55438 core, and 53 turns of four-strand 18 AWG wire.

4 Efficiency Curves

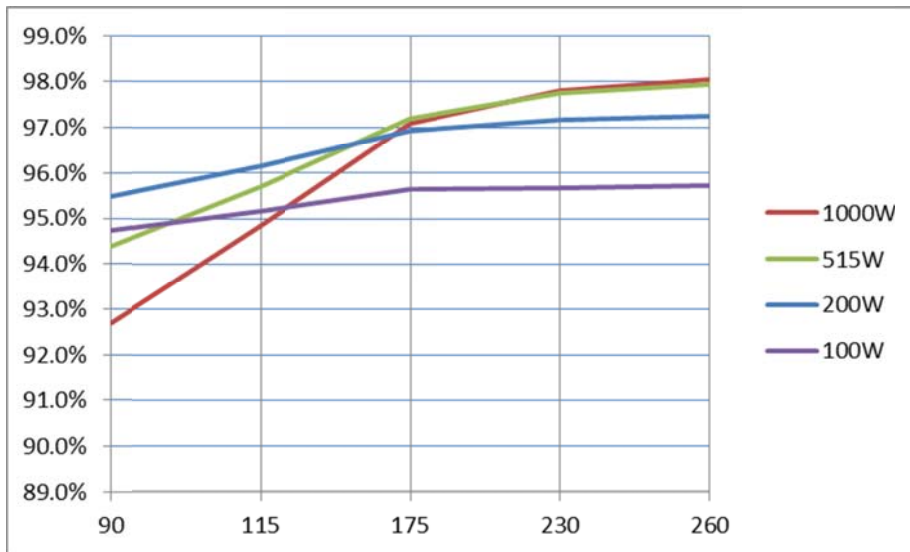

Figure 3: Efficiency versus AC input voltage curve for a 91 kHz hard switched PFC

The Figure 3 efficiency curves versus input voltage were run for loads detailed in the 80 Plus specifications (10%, 20%, 50% and 100% of rated load) for a 1 kW PFC stage. These efficiency results will be used in the context of the 80 Plus certificates of Gold, Platinum and Titanium. The 80 Plus specification calls out two efficiencies at 230VAC, so in this comparison, when the efficiencies differ, the higher efficiency will be used.

5 80 Plus Gold

Figure 4 superimposes the efficiency measurements from the previous graph onto the 80 Plus Gold specification. All power factor measurements are greater than 0.95, and at the higher power ratings are in the 0.99 range.

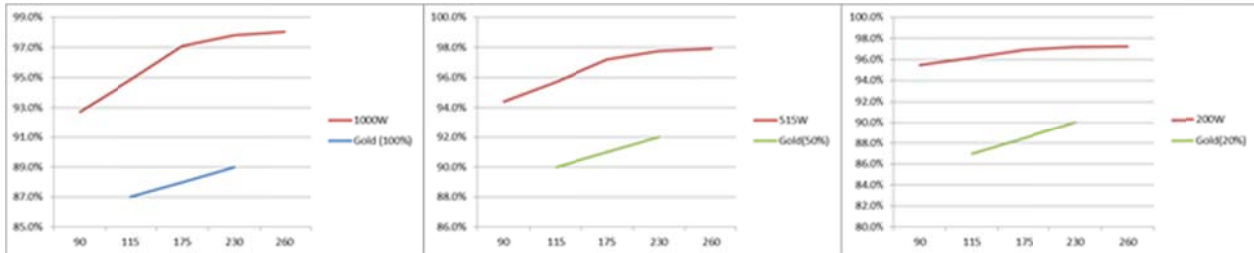

Figure 4 Efficiency versus AC input voltage curves for 1 kW PFC demonstration board compared to the 80 Plus Gold requirements

The efficiencies achieved well exceed the 80 Plus Gold specification, but as mentioned before, the 90 Plus spec is for the complete power supply, not just the PFC stage. The narrowest delta is 5.7% points at low line for the 50% load line. This equates to the final power conversion stage needing to meet or exceed 94% efficiency at this load line. As the secondary stage is operating from a regulated output and therefore allows for straightforward optimization, this should be well within a designer's reach without extraordinary efforts.

6 80 Plus Platinum

Figure 5 superimposes the Platinum rating on the initial efficiency measurements. As mentioned previously, all power factors are within the 80 Plus specification.

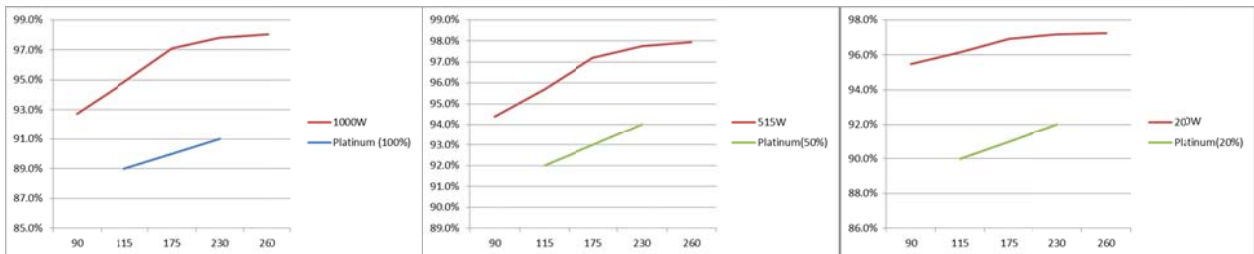

Figure 5: Efficiency versus AC input voltage curves for 1 kW PFC demonstration board compared to the 80 Plus Platinum requirements

The lowest efficiency delta between the specification and board is 3.7% points, once again at low line at the 50% load point. This corresponds to a final power conversion stage requirement of 96.1% to meet the Platinum rating. Obviously this is more difficult than Gold, but achievable. The average delta is 5.7%, so it is even possible to adjust Rg, switching frequency, or inductor design to improve the tradeoff at this operating point if the system does not quite meet the Platinum rating.

7 80 Plus Titanium

The Titanium specification is the most difficult to meet and typically reserved for servers. Figure 6 lays out the efficiencies in the same pattern as before, although the additional 10% load of Titanium has been added to the 20% load graph.

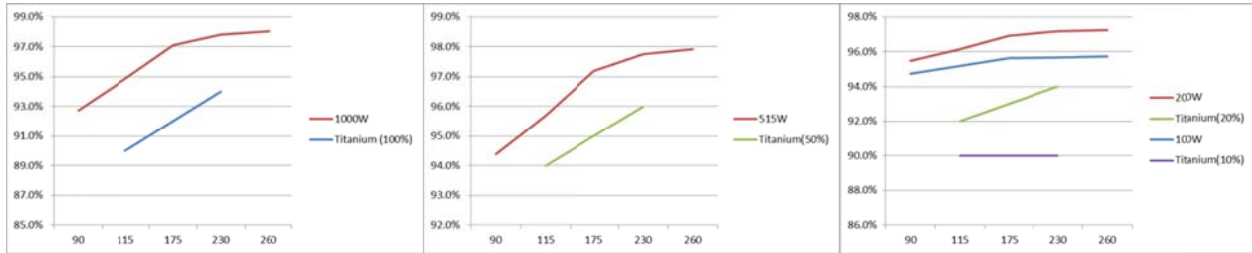

Figure 6: Efficiency versus AC input voltage curves for 1 kW PFC demonstration board compared to the 80 Plus Titanium requirements

The narrowest delta, once again at the low line 50% load point is 1.7% percentage points between the PFC efficiency and the 80 Plus Titanium specification. This leaves the final conversion power stage efficiency requirement to be 98.2%; not an impossible task, and achievable with the latest Phase Shift Bridge and LLC topologies.

8 Summary

It is hoped that this application note has shown that the hard switched current average PFC is very viable in Gold rated 80 Plus supplies, and a plausible option for the higher efficiency Platinum and Titanium ratings. The low R_{ds} and switching speeds of USCI's 650V silicon carbide cascodes and JBS diodes give designers component options when looking to meet the latest efficiency and power factor requirements in today's high volume computer systems.